

PREPARED BY : DATE

*M. Mayumi Jul. 1. 1999*

APPROVED BY : DATE

*H. Koushi Jul. 1. 1999*

# SHARP

LCD DEVELOPMENT GROUP  
SHARP CORPORATION

## SPECIFICATION

SPEC No. LCY-99101

FILE No.

ISSUE : Jul. 1, 1999

PAGE : 20 pages

APPLICABLE GROUP

DEVELOPMENT ENGINEERING DEPT. II

TFT DIVISION. I

TFT LCD GROUP

DEVICE SPECIFICATION FOR

# TFT-LCD Module

MODEL No.

# LQ10D367

CUSTOMER'S APROVAL

DATE

BY

PRESENTED

BY

*S. Yasuda*  
S. YASUDA

Department General Manager

TFT DIVISION. I

TFT LCD GROUP

SHARP CORPORATION

## 1. Application

This specification applies to color TFT-LCD module, LQ10D367.

These specification sheets are the proprietary product of SHARP CORPORATION ("SHARP") and include materials protected under copyright of SHARP. Do not reproduce or cause any third party to reproduce them in any form or by any means, electronic or mechanical, for any purpose in whole or in part, without the express written permission of SHARP.

The device listed in these specification sheets was designed and manufactured for use in general electronic equipment.

In case of using the device for applications such as control and safety equipment for transportation (aircraft, trains, automobiles, etc.), rescue and security equipment and various safety related equipment which require higher reliability and safety, take into consideration that appropriate measures such as fail-safe functions and redundant system design should be taken.

Do not use the device for equipment that requires an extreme level of reliability, such as aerospace applications, telecommunication equipment (trunk lines), nuclear power control equipment and medical or other equipment for life support.

SHARP assumes no responsibility for any damage resulting from the use of the device which does not comply with the instructions and the precautions specified in these specification sheets.

Contact and consult with a SHARP sales representative for any questions about this device.

## 2. Overview

This module is a color active matrix LCD module incorporating amorphous silicon TFT (Thin Film Transistor). It is composed of a color TFT-LCD panel, driver ICs, control circuit and power supply circuit and a backlight unit. Graphics and texts can be displayed on a  $640 \times 3 \times 480$  dots panel with 262,144 colors by supplying 18 bit data signal (6bit/color), four timing signals, +5V DC supply voltage for TFT-LCD panel driving and supply voltage for backlight.

The TFT-LCD panel used for this module is a low-reflection and higher-color-saturation type. Therefore, this module is also suitable for the multimedia use. Viewing angle is 6 o'clock direction.

This module is the type of wide viewing angle and high brightness ( $200\text{cd/m}^2$ ).

Backlight-driving DC/AC inverter is not built in this module.

## 3. Mechanical Specifications

Parameter	Specifications	Unit
Display size	26 (10.4") Diagonal	cm
Active area	211.2(H)×158.4(V)	mm
Pixel format	640(H)×480(V)	pixel
	(1 pixel=R+G+B dots)	—
Pixel pitch	0.330(H)×0.330(V)	mm
Pixel configuration	R,G,B vertical stripe	—
Display mode	Normally white	—
Unit outline dimensions *1	246.5(W)×179.4(H)×10.5(D)	mm
Mass	550±20	g
Surface treatment	Anti-glare and hard-coating 3H Haze value = 28 %	—

\*1.Note: excluding backlight cables.

Outline dimensions is shown in Fig.1

4. Input Terminals

4-1. TFT-LCD panel driving

CN1 Used connector:DF9BA-31P-1V (Hirose Electric Co., Ltd.)

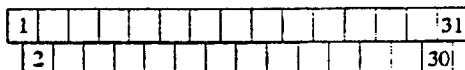

CN1 pin arrangement from module surface  
(Transparent view)

Corresponding connector: DF9 -31S-1V ( // )

DF9A-31S-1V ( // )

DF9B-31S-1V ( // )

DF9M-31S-1V ( // )

Pin No.	Symbol	Function	Remark
1	GND	—	—
2	CK	Clock signal for sampling each data signal	—
3	Hsync	Horizontal synchronous signal	【Note1】
4	Vsync	Vertical synchronous signal	【Note1】
5	GND	—	—
6	R0	R E D data signal(LSB)	—
7	R1	R E D data signal	—
8	R2	R E D data signal	—
9	R3	R E D data signal	—
10	R4	R E D data signal	—
11	R5	R E D data signal(MSB)	—
12	GND	—	—
13	G0	G R E E N data signal(LSB)	—
14	G1	G R E E N data signal	—
15	G2	G R E E N data signal	—
16	G3	G R E E N data signal	—
17	G4	G R E E N data signal	—
18	G5	G R E E N data signal(MSB)	—
19	GND	—	—
20	B0	B L U E data signal(LSB)	—
21	B1	B L U E data signal	—
22	B2	B L U E data signal	—
23	B3	B L U E data signal	—
24	B4	B L U E data signal	—
25	B5	B L U E data signal(MSB)	—
26	GND	—	—
27	ENAB	Signal to settle the horizontal display position	【Note2】
28	Vcc	+5.0V power supply	—
29	Vcc	+5.0V power supply	—
30	R/L	Horizontal display mode select signal	【Note3】
31	U/D	Vertical display mode select signal	【Note4】

※The shielding case is not connected with GND.

【Note1】 480 line, 400 line or 350 line mode is selected by the polarity combination of the both synchronous signals.

Mode	480 lines	400 lines	350 lines
Hsync	negative	negative	positive
Vsync	negative	positive	negative

【Note2】 The horizontal display start timing is settled in accordance with a rising timing of ENAB signal. In case ENAB is fixed "Low", the horizontal start timing is determined as described in 7-2. Don't keep ENAB "High" during operation.

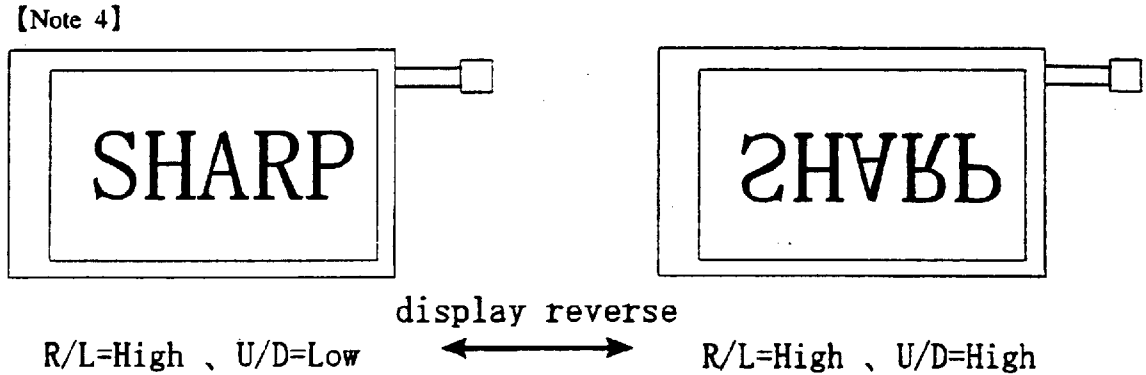
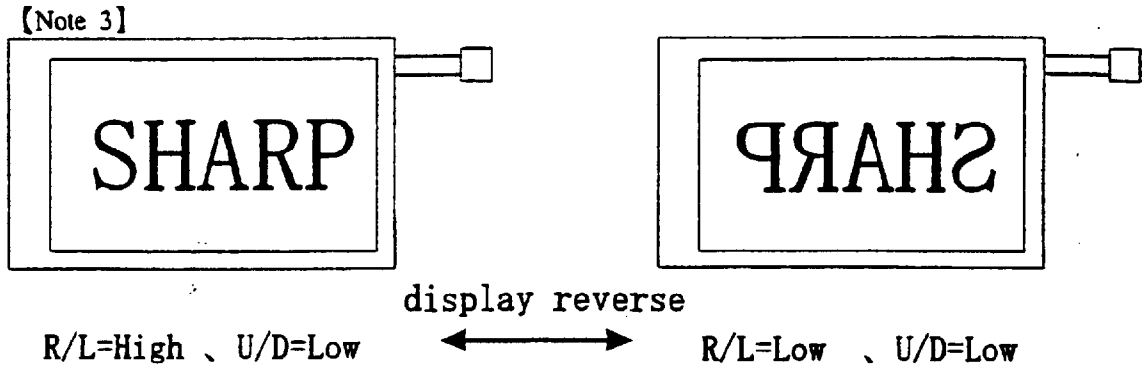

4-2. Backlight driving

Used connector : BHR-03VS-1(JST)

CN 2

Corresponding connector : SM02(8.0)B-BHS(JST)

Pin no.	symbol	function
1	V <sub>HIGH</sub>	Power supply for lamp (High voltage side)
2	NC	This is electrically opened.
3	V <sub>LOW</sub>	Power supply for lamp (Low voltage side)

5. Absolute Maximum Ratings

Parameter	Symbol	Condition	Ratings	Unit	Remark
Input voltage	V <sub>I</sub>	T <sub>a</sub> =25°C	-0.3 ~ V <sub>CC</sub> +0.3	V	【Note1】
+5V supply voltage	V <sub>CC</sub>	T <sub>a</sub> =25°C	0 ~ +6	V	-
Storage temperature	T <sub>stg</sub>	-	-25 ~ +70	°C	【Note2】
Operating temperature (Ambient)	T <sub>opa</sub>	-	0 ~ +50	°C	

【Note1】 CK,R0~R5,G0~G5,B0~B5,Hsync,Vsync,ENAB,R/L,U/D

【Note2】 Humidity : 95%RH Max. at T<sub>a</sub> ≤ 40°C.

Maximum wet-bulb temperature at 39°C or less at T<sub>a</sub> > 40°C.

No condensation.

6. Electrical Characteristics

6-1. TFT-LCD panel driving

Ta=25°C

Parameter		Symbol	Min.	Typ.	Max.	Unit	Remark
+5V	Supply voltage	Vcc	+4.5	+5.0	+5.5	V	[Note1]
	Current dissipation	Icc	—	280	450	mA	[Note2]
Permissive input ripple voltage		V <sub>RF</sub>	—	—	100	mVp-p	V <sub>cc</sub> =+5V
Input voltage (Low)		V <sub>IL</sub>	—	—	0.3V <sub>cc</sub>	V	[Note3]
Input voltage (High)		V <sub>IH</sub>	0.7V <sub>cc</sub>	—	—	V	
Input current (low)		I <sub>OL1</sub>	—	—	1.0	μA	V <sub>I</sub> =0V [Note4]
		I <sub>OL2</sub>	—	—	60.0	μA	V <sub>I</sub> =0V [Note5]
Input current (High)		I <sub>OH1</sub>	—	—	1.0	μA	V <sub>I</sub> =V <sub>cc</sub> [Note6]
		I <sub>OH2</sub>	—	—	60.0	μA	V <sub>I</sub> =V <sub>cc</sub> [Note7]

【Note1】

Vcc-turn-on conditions

- 0 < t<sub>1</sub> ≤ 20 ms
- 0 < t<sub>2</sub> ≤ 20 ms
- 0 < t<sub>3</sub> ≤ 1 s
- t<sub>4</sub> > 1 s

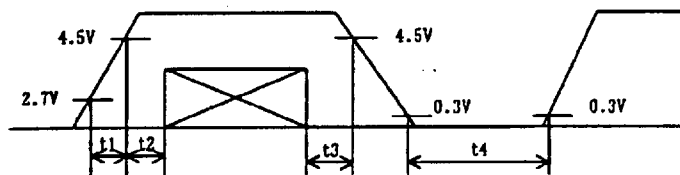

Vcc-dip conditions

- 1) 2.7V ≤ V<sub>cc</sub> < 4.5V  
t<sub>d</sub> ≤ 10ms
- 2) V<sub>cc</sub> < 2.7V

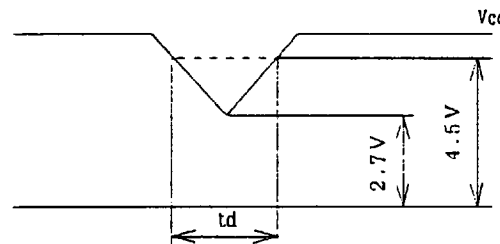

Vcc-dip conditions should also follow the Vcc-turn-on conditions

【Note2】 Typical current situation : 16-gray-bar pattern.

480 line mode

V<sub>cc</sub>=+5.0V

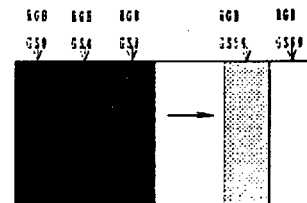

【Note3】 CK,R0~R5,G0~G5,B0~B5,Hsync,Vsync,ENAB,R/L,U/D

【Note4】 CK,R0~R5,G0~G5,B0~B5,Hsync,Vsync,ENAB

【Note5】 R/L

【Note6】 CK,R0~R5,G0~G5,B0~B5,Hsync,Vsync

【Note7】 ENAB,U/D

6-2. Backlight driving

The backlight system is an edge-lighting type with CCFT (Cold Cathode Fluorescent Tube).

The characteristics are shown in the following table.

Ta=25°C

Parameter	Symbol	Min.	Typ.	Max.	Unit	Remark
Lamp current	IL	2.0	6.0	6.5	mArms	[Note1]
Lamp power consumption	PL	—	3.0	—	W	[Note2]
Lamp frequency	FL	20	35	60	KHz	[Note3]
Kick-off voltage	Vs	—	—	950	Vrms	Ta=25°C
		—	—	1400	Vrms	Ta=0°C [Note4]
Lamp life time	Lt	—	50000	—	hour	[Note5]

[Note1] Lamp current is measured with current meter for high frequency as shown below.

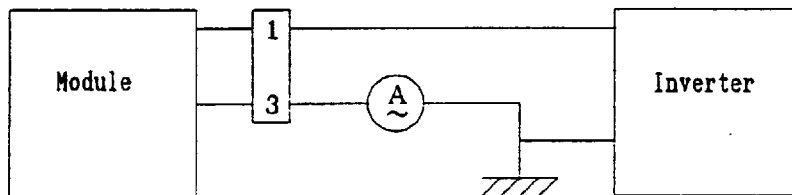

\* 3pin is V<sub>LOW</sub>

[Note2] At the condition of  $Y_L = 200 \text{ cd/m}^2$

[Note3] Lamp frequency may produce interference with horizontal synchronous frequency, and this may cause beat on the display. Therefore lamp frequency shall be detached as much as possible from the horizontal synchronous frequency and from the harmonics of horizontal synchronous to avoid interference.

[Note4] The open output voltage of the inverter shall be maintained for more than 1sec; otherwise the lamp may not be turned on.

[Note5] a) Since lamp is consumables, the life time written above is referencial value and it is not guaranteed in this specification sheet by SHARP.

Lamp life time is defined that it applied either ① or ② under this condition

(Continuous turning on at Ta=25°C, IL=6mArms)

① Brightness becomes 50% of the original value under standard condition.

② Kick-off voltage at Ta=0°C exceeds maximum value, 1400 Vrms.

b) In case of operating under lower temp environment, the lamp exhaustion is accelerated and the brightness becomes lower.

(Continuous operating for around 1 month under lower temp condition may reduce the brightness to half of the original brightness.)

In case of such usage under lower temp environment, periodical lamp exchange is recommended.

Note) The performance of the backlight, for example life time or brightness, is much influenced by the characteristics of the DC-AC inverter for the lamp. When you design or order the inverter, please make sure that a poor lighting caused by the mismatch of the backlight and the inverter (miss-lighting, flicker, etc.) never occur. when you confirm it, the module should be operated in the same condition as it is installed in your instrument.

7. Timing Characteristics of input signals

Timing diagrams of input signal are shown in Fig.2-1~3.

7-1. Timing characteristics

Parameter	Symbol	Mode	Min.	Typ.	Max.	Unit	Remark	
Clock	Frequency	1/Tc	all	—	25.18	28.33	MHz	—
	High time	Tch	//	5	—	—	ns	—
	Low time	Tcl	//	10	—	—	ns	—
Data	Setup time	Tds	//	5	—	—	ns	—
	Hold time	Tdh	//	10	—	—	ns	—
Horizontal sync. signal	Cycle	TH	//	30.00	31.78	—	μs	—
			//	750	800	900	clock	—
	Pulse width	THp	//	2	96	200	clock	—
Vertical sync. signal	Cycle	TV	480	515	525	560	line	—
			400	446	449	480	line	—
			350	447	449	510	line	—
	Pulse width	TVp	all	1	—	34	line	—
Horizontal display period	THd	//	640	640	640	clock	—	
Hsync-Clock phase difference	THc	//	10	—	Tc-10	ns	—	
Hsync-Vsync phase difference	TVh	//	0	—	TH-THp	clock	—	

Note) In case of lower frequency, the deterioration of display quality, flicker etc..may be occurred.

7-2. Horizontal display position

The horizontal display position is determined by ENAB signal and the input data corresponding to the rising edge of ENAB signal is displayed at the left end of the active area.

Parameter	symbol	Min.	Typ.	Max.	Unit	Remark	
Enable signal	Setup time	Tes	5	—	Tc-10	ns	—
	Pulse width	Tep	2	640	640	clock	—
Hsync-Enable signal phase difference	THE	44	—	TH-664	clock	—	

Note) When ENAB is fixed "Low", the display starts from the data of C104(clock) as shown in Fig.2-1~3. Be careful that the module does not work when ENAB is fixed "High".

7-3. Vertical display position

The vertical display position is automatically centered in the active area at each mode of VGA,480-,400-,and 350-line mode. Each mode is selected depending on the polarity of the synchronous signals described in 4-1(Note1).



In each mode, the data of TVn is displayed at the top line of the active area. And the display position will be centered on the screen like the following figure when the period of vertical synchronous signal, TV, is typical value.

In 400-, and 350-line mode, the data in the vertical data invalid period is also displayed. So, inputting all data "0" is recommended during vertical data invalid period.

ENAB signal has no relation to the vertical display position.

mode	V-data start(TVs)	V-data period(TVd)	V-display start(TVn)	V-display period	Unit	Remark
480	34	480	34	480	line	—
400	34	400	443-TV	480	line	—
350	61	350	445-TV	480	line	—

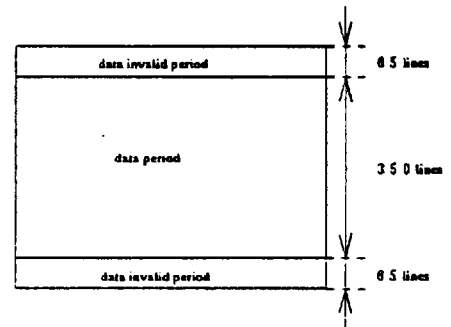
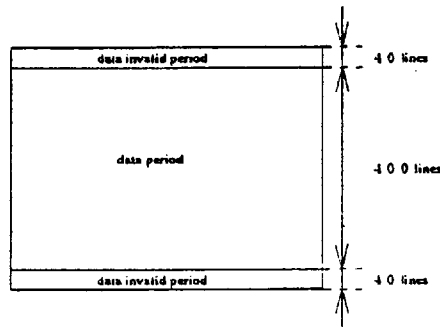

7-4. Input Data Signals and Display Position on the screen

Display position of input data (480 lines mode)

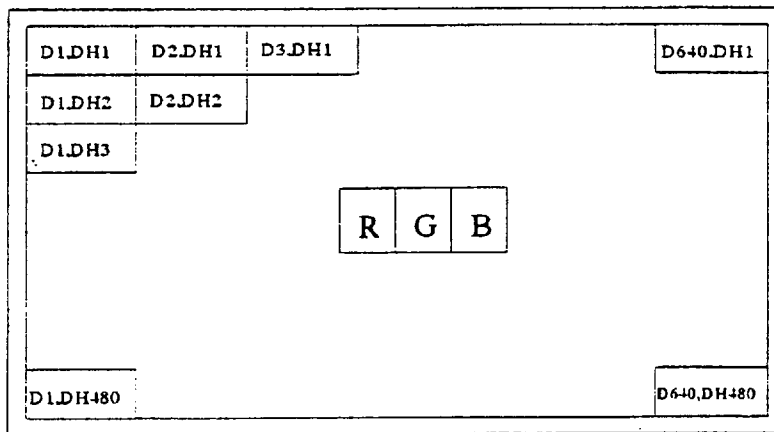

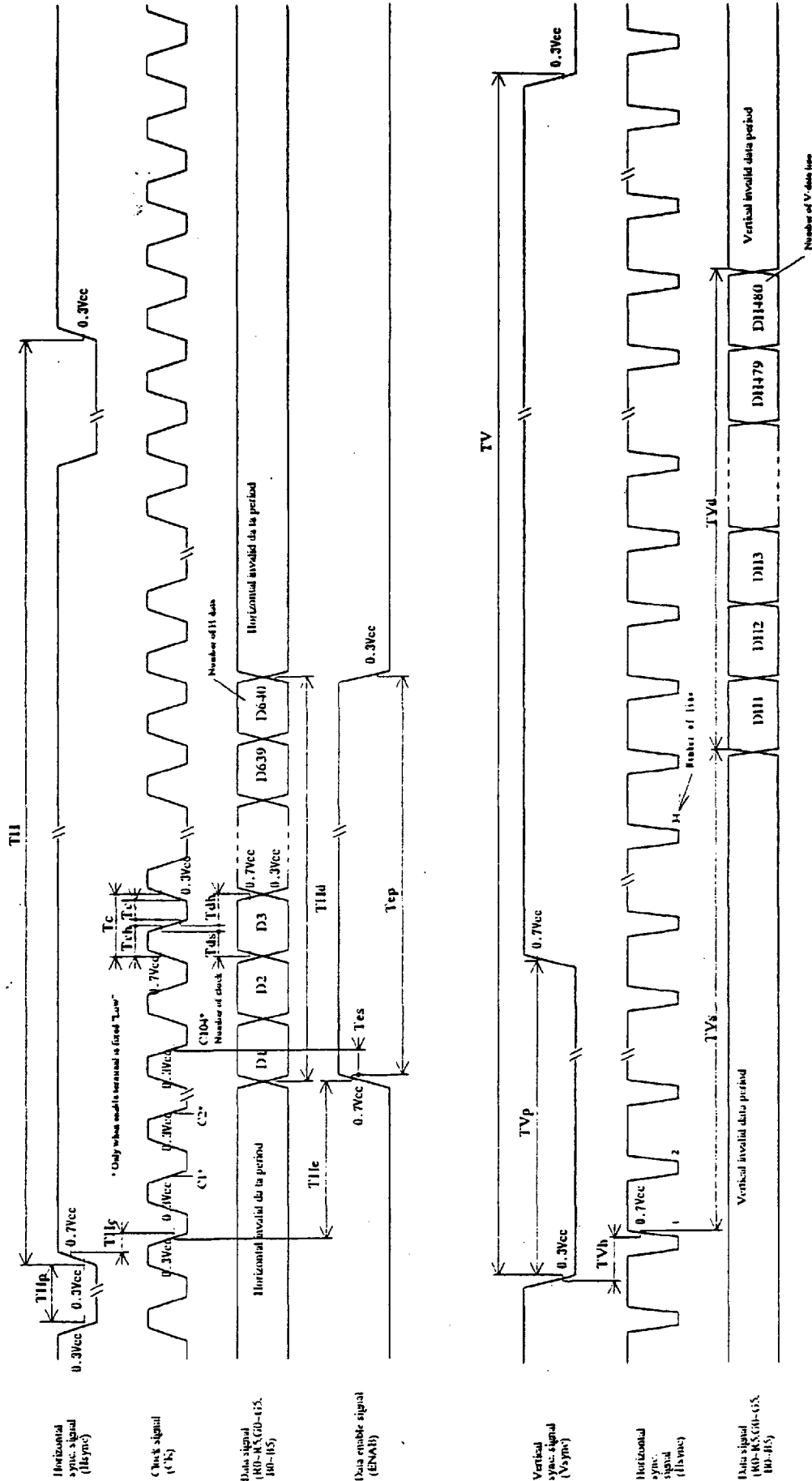

Fig 2-1 Input signal waveforms (480 line mode)

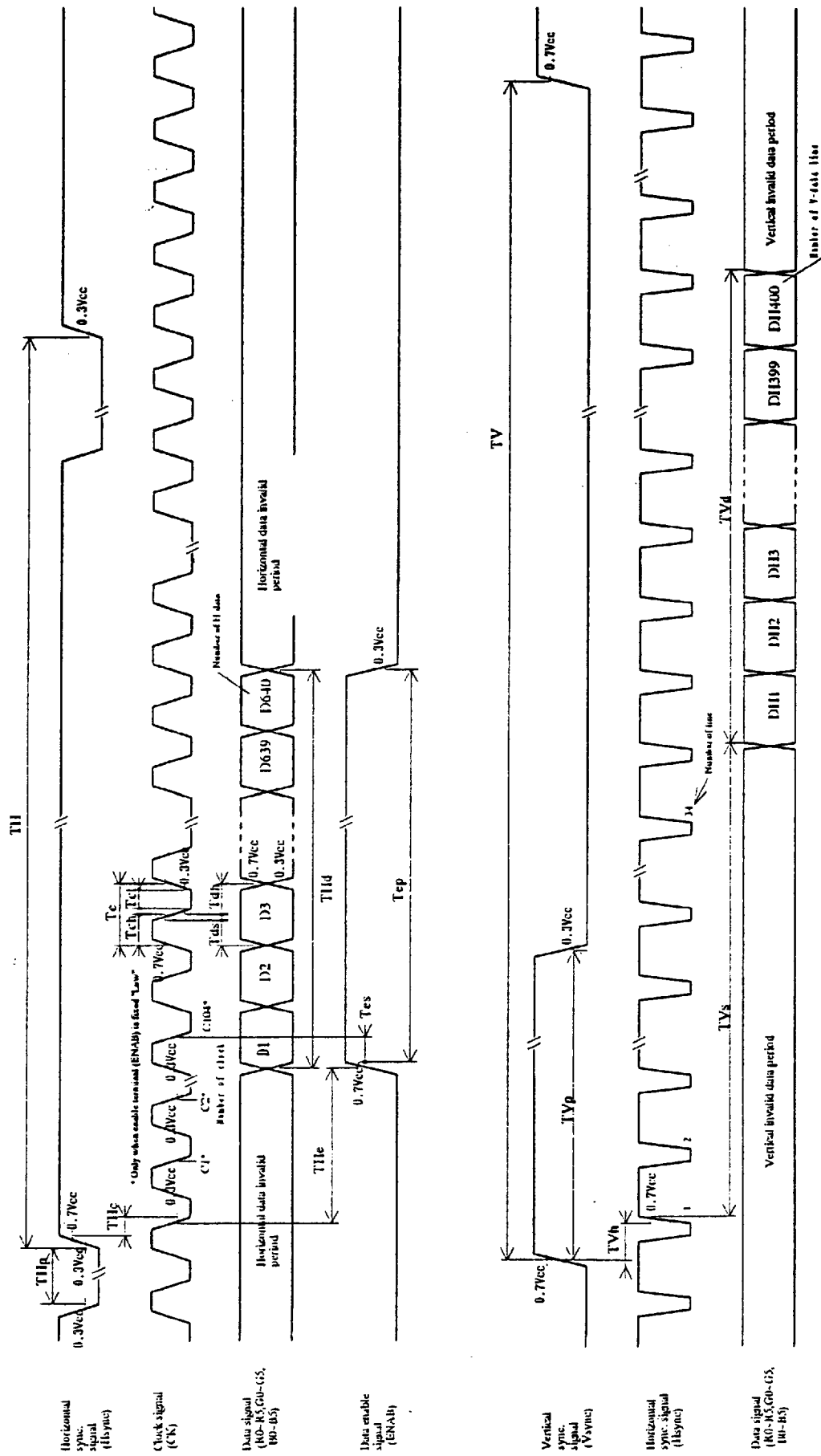

Fig.2-2 Input signal waveforms (400 line mode)

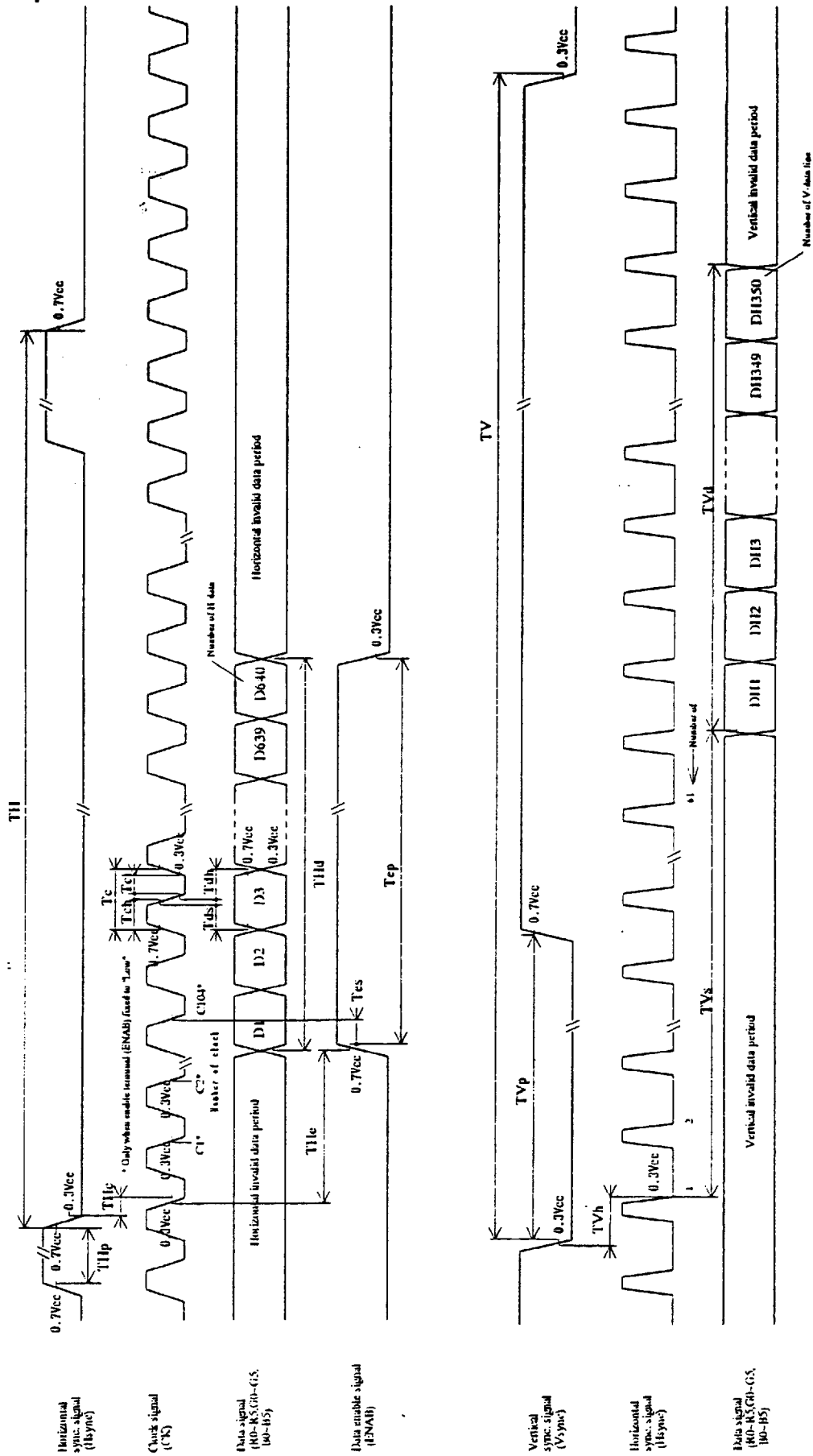

Fig.2-3 Input signal waveforms (350 line mode)

8. Input Signals, Basic Display Colors and Gray Scale of Each Color

	Colors & Gray scale	Data signal																		
		GrayScale	R0	R1	R2	R3	R4	R5	G0	G1	G2	G3	G4	G5	B0	B1	B2	B3	B4	B5
Basic color	Black	—	0	0	0	0	0	0	0	0	0	0	0	0	0	0	0	0	0	0
	Blue	—	0	0	0	0	0	0	0	0	0	0	0	0	1	1	1	1	1	1
	Green	—	0	0	0	0	0	0	1	1	1	1	1	1	0	0	0	0	0	0
	Cyan	—	0	0	0	0	0	0	1	1	1	1	1	1	1	1	1	1	1	1
	Red	—	1	1	1	1	1	1	0	0	0	0	0	0	0	0	0	0	0	0
	Magenta	—	1	1	1	1	1	1	0	0	0	0	0	0	1	1	1	1	1	1
	Yellow	—	1	1	1	1	1	1	1	1	1	1	1	1	0	0	0	0	0	0
	White	—	1	1	1	1	1	1	1	1	1	1	1	1	1	1	1	1	1	1
Gray Scale of red	Black	GS0	0	0	0	0	0	0	0	0	0	0	0	0	0	0	0	0	0	0
	↑	GS1	1	0	0	0	0	0	0	0	0	0	0	0	0	0	0	0	0	0
	Darker	GS2	0	1	0	0	0	0	0	0	0	0	0	0	0	0	0	0	0	0
	↑	↓				↓					↓						↓			
	↓	↓				↓					↓						↓			
	Brighter	GS61	1	0	1	1	1	1	0	0	0	0	0	0	0	0	0	0	0	0
	↓	GS62	0	1	1	1	1	1	0	0	0	0	0	0	0	0	0	0	0	0
	Red	GS63	1	1	1	1	1	1	0	0	0	0	0	0	0	0	0	0	0	0
Gray Scale of green	Black	GS0	0	0	0	0	0	0	0	0	0	0	0	0	0	0	0	0	0	0
	↑	GS1	0	0	0	0	0	0	1	0	0	0	0	0	0	0	0	0	0	0
	Darker	GS2	0	0	0	0	0	0	0	1	0	0	0	0	0	0	0	0	0	0
	↑	↓				↓					↓						↓			
	↓	↓				↓					↓						↓			
	Brighter	GS61	0	0	0	0	0	0	1	0	1	1	1	1	0	0	0	0	0	0
	↓	GS62	0	0	0	0	0	0	0	1	1	1	1	1	0	0	0	0	0	0
	Green	GS63	0	0	0	0	0	0	1	1	1	1	1	1	0	0	0	0	0	0
Gray Scale of blue	Black	GS0	0	0	0	0	0	0	0	0	0	0	0	0	0	0	0	0	0	0
	↑	GS1	0	0	0	0	0	0	0	0	0	0	0	0	1	0	0	0	0	0
	Darker	GS2	0	0	0	0	0	0	0	0	0	0	0	0	0	1	0	0	0	0
	↑	↓				↓					↓						↓			
	↓	↓				↓					↓						↓			
	Brighter	GS61	0	0	0	0	0	0	0	0	0	0	0	0	1	0	1	1	1	1
	↓	GS62	0	0	0	0	0	0	0	0	0	0	0	0	0	1	1	1	1	1
	Blue	GS63	0	0	0	0	0	0	0	0	0	0	0	0	1	1	1	1	1	1

0 : Low level voltage, 1 : High level voltage

Each basic color can be displayed in 64 gray scales from 6 bit data signals. According to the combination of total 18 bit data signals, the 262,144-color display can be achieved on the screen.

9. Optical Characteristics

Ta=25°C, Vcc=+5V

Parameter		Symbol	Condition	Min.	Typ.	Max.	Unit	Remark
Viewing angle range	Horizontal	$\theta_{21}$	(CR $\geq$ 5)	60	70	—	Deg.	[Note1,4]
		$\theta_{22}$		60	70	—	Deg.	
	Vertical	$\theta_{11}$		35	40	—	Deg.	
		$\theta_{12}$		55	70	—	Deg.	
Contrast ratio		CR	$\theta=0^\circ$	150	—	—	—	[Note2,4]
			Best viewing angle	—	300	—	—	
Response time	Rise	$\tau_r$	$\theta=0^\circ$	—	20	—	ms	[Note3,4]
	Decay	$\tau_d$		—	40	—	ms	
Chromaticity of white		X		—	0.313	—	—	[Note4]
		Y		—	0.329	—	—	
Luminance of white		Y <sub>L</sub>		160	200	—	cd/m <sup>2</sup>	
White Uniformity		$\delta_w$		—	—	1.45	—	[Note5]
Viewing angle range as a brightness definition	Horizontal	$\theta_{21}$	50% of the maximum brightness	—	45	—	Deg.	[Note1] Reference data
		$\theta_{22}$		—	45	—	Deg.	
	Vertical	$\theta_{11}$		—	35	—	Deg.	
		$\theta_{12}$		—	30	—	Deg.	

\*The measurement shall be executed 30 minutes after lighting at rating. (typical condition: I<sub>L</sub>=6mA rms)  
 The optical characteristics shall be measured in a dark room or equivalent state with the method shown in Fig.3 below.

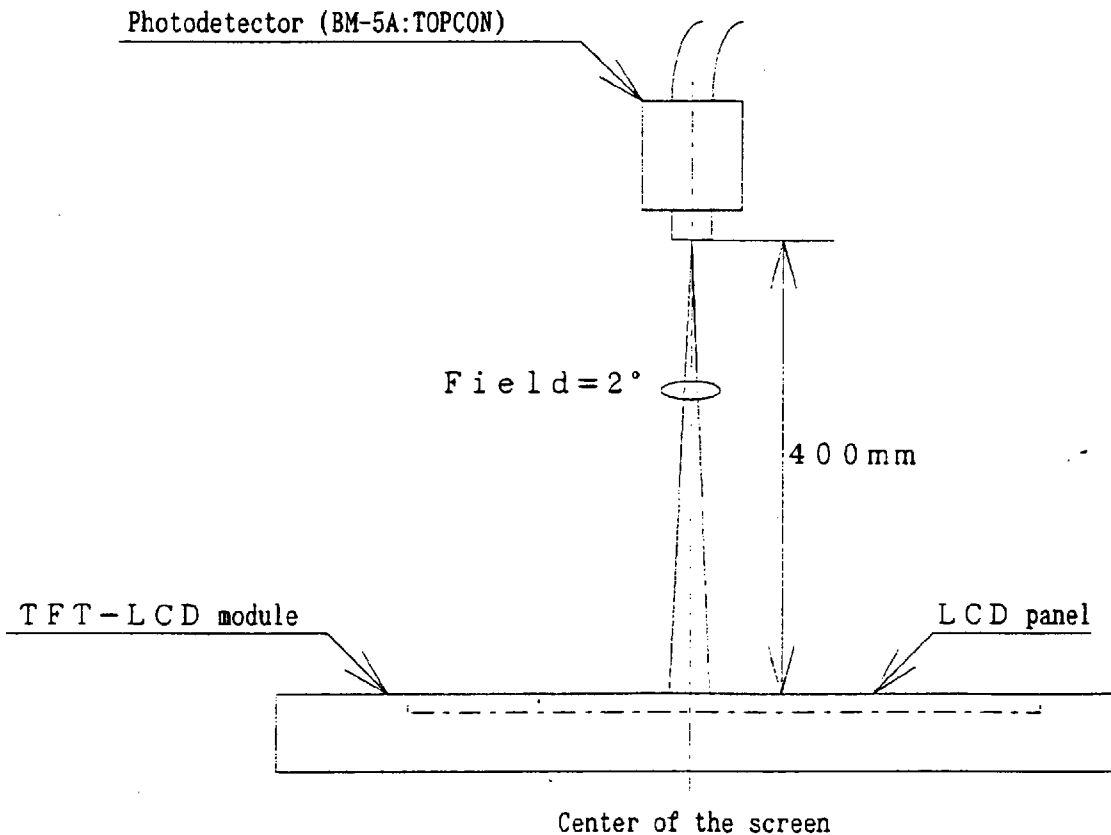
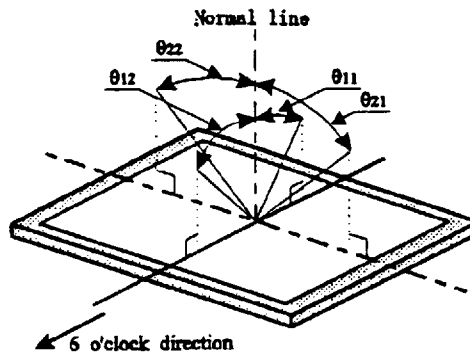

Fig.3 Optical characteristics measurement method

**[Note1]** Definitions of viewing angle range:



**[Note2]** Definition of contrast ratio:

The contrast ratio is defined as the following.

$$\text{Contrast Ratio (CR)} = \frac{\text{Luminance (brightness) with all pixels white}}{\text{Luminance (brightness) with all pixels black}}$$

**[Note3]** Definition of response time:

The response time is defined as the following figure and shall be measured by switching the input signal for "black" and "white".

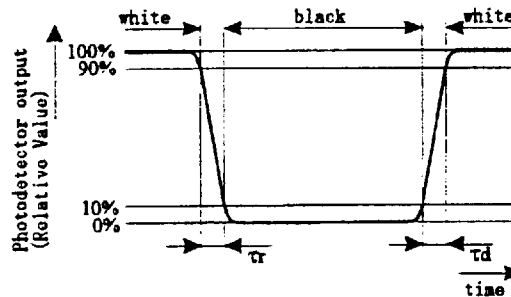

**[Note4]** This shall be measured at center of the screen.

**[Note5]** Definition of white uniformity:

White uniformity is defined as the following with five measurements (A~E).

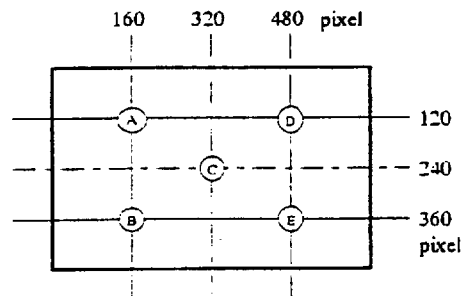

$$\delta_w = \frac{\text{Maximum Luminance of five points (brightness)}}{\text{Minimum Luminance of five points (brightness)}}$$

## 10. Display Quality

The display quality of the color TFT-LCD module shall be in compliance with the Incoming Inspection Standard.

## 11. Handling Precautions

- a) Be sure to turn off the power supply when inserting or disconnecting the cable.
- b) Be sure to design the cabinet so that the module can be installed without any extra stress such as warp or twist.
- c) Since the front polarizer is easily damaged, pay attention to avoid rubbing with something hard or sharp.
- d) Wipe off water drop immediately. Long contact with water may cause discoloration or spots.
- e) When the panel surface is soiled, wipe it with absorbent cotton or other soft cloth.
- f) Since the panel is made of glass and refined wires and components, it may break, crack or internal wire breaking if dropped or bumped on hard surface.  
Handle with care.
- g) Since CMOS LSI is used in this module, take care of static electricity and injure the human earth when handling.
- h) Observe all other precautionary requirements in handling components.
- i) This module has its circuitry PCBs on the rear side and should be carefully handled in order not to be stressed.
- j) Laminated film is attached to the module surface to prevent it from being scratched. Peel the film off slowly, just before the use, with strict attention to electrostatic charges. Ionized air shall be blown over during the action. Blow off 'dust' on the polarizer by using an ionized nitrogen gun, etc.
- k) The polarizer surface on the panel is treated with Anti-Glare for low reflection. In case of attaching protective board over the LCD. Be careful about the optical interference fringe etc.  
Which degrades display quality.
- l) Connect GND to 4 place of mounting holes to stabilize against EMI and external noise.
- m) There are high voltage portions on the backlight and very dangerous. Careless touch may lead to electrical shock. When exchange lamps or service. Turn off the power without fail.

## 12. Packing form

- a) Piling number of cartons : MAX.7
- b) Package quantity in one carton : 10 pcs
- c) Carton size : 298(W) × 295(D) × 362(H)mm
- d) Total mass of 1 carton filled with full modules : 8kg



## 13. Reliability test items

No.	Test item	Conditions
1	High temperature storage test	Ta=70°C 240h
2	Low temperature storage test	Ta=-25°C 240h
3	High temperature & high humidity operation test	Ta=40°C ; 95%RH 240h (No condensation)
4	High temperature operation test	Ta=50°C 240h
5	Low temperature operation test	Ta=0°C 240h
6	Vibration test (non- operating)	Frequency : 10~57Hz/Vibration width (one side):0.075mm : 58~500Hz/Gravity:9.8m/s <sup>2</sup> Sweep time : 11 minutes Test period : 3 hours (1 hour for each direction of X,Y,Z)
7	Shock test (non- operating)	Max. gravity : 490m/s <sup>2</sup> Pulse width : 11ms, half sine wave Direction : ±X, ±Y, ±Z once for each direction.

## 【Result Evaluation Criteria】

Under the display quality test conditions with normal operation state, these shall be no change which may affect practical display function.

## 14. Others

1) Lot No. Label:

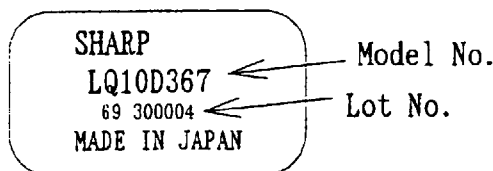

2) Adjusting volume have been set optimally before shipment, so do not change any adjusted value.

If adjusted value is changed, the specification may not be satisfied.

3) Disassembling the module can cause permanent damage and should be strictly avoided.

4) Please be careful since image retention may occur when a fixed pattern is displayed for a long time.

5) If any problem occurs in relation to the description of this specification , it shall be resolved through discussion with spirit of cooperation.

6) Do not use LCD module in the atmosphere of corrosive gases, such as sulfide gas or chlorine gases. Polarizer may be deteriorated or cause chemical reaction that can lead to short circuits at the terminal points. Do not use the material, which compounds contain sulfide or chlorine articles in the vicinity of LCD module. At high temperature, these compounds produce corrosive gases.

**[EXCHANGING THE LAMP UNIT]**

The lamp in the LCD module is consumable and when needed, please replace them including lamp holder in accordance with following 1) - 5) procedure.

※Before exchanging the lamp unit, turn off the power of the inverter without fail.

- 1) The lamp holder①is fixed with the rear side board②by fitting the projection③of the lamp holder to the hole④of the rear side board. (refer to fig 4)
- 2) The projection can be relieved by bending the rear side board to the direction A with hand or minus driver. (refer to fig 5)
- 3) Draw out the lamp holder①to the direction B, bending the board②.(refer to fig 6)
- 4) Insert the spare lamp holder to the direction C.(refer to the fig 6)
- 5) Push the lamp holder①to the position which the projection③is fit in the hole④ of rear side board②.

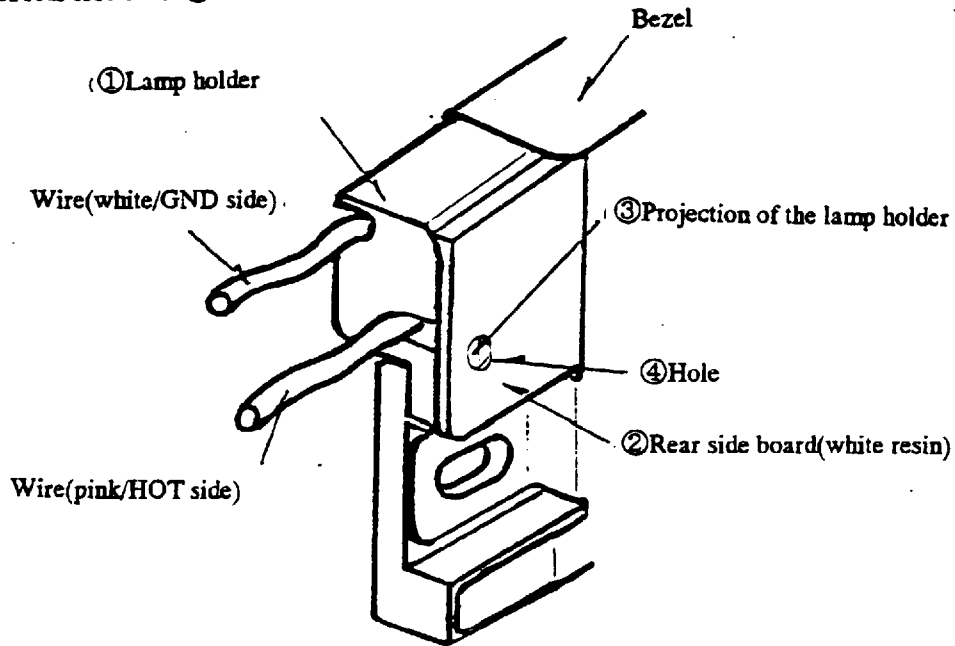

Fig.4

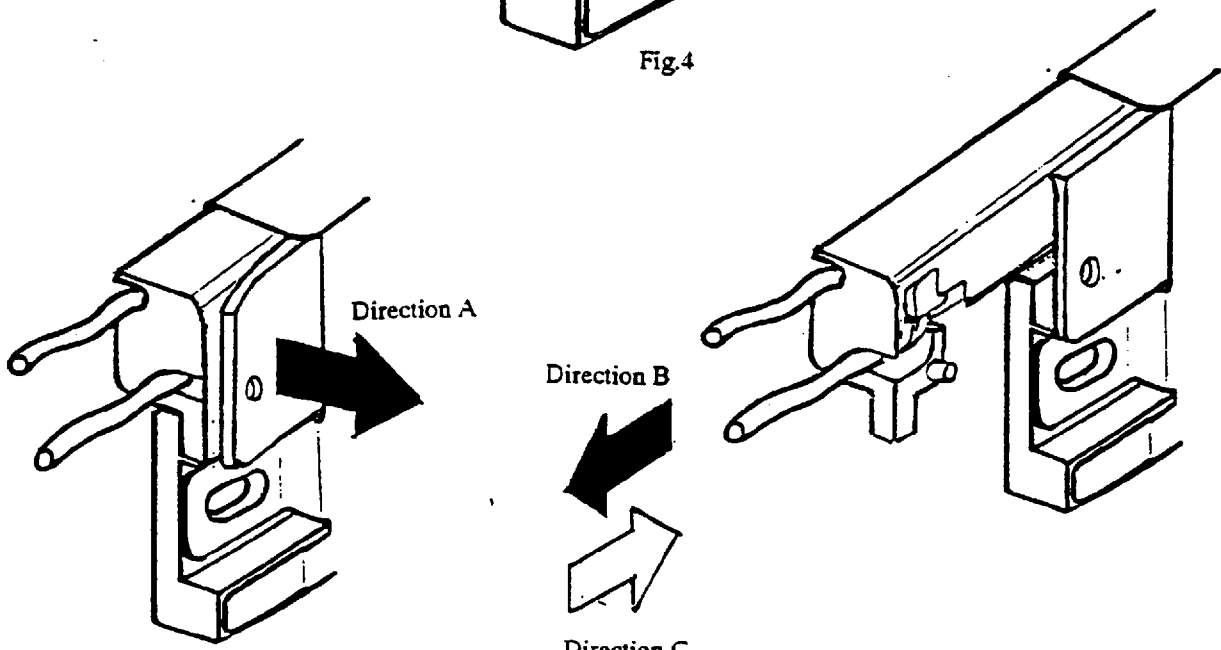

Fig.5

Fig.6

